

Experimental Investigation of Mixer Plate Temperature and Wall Impingement Regimes in Selective Catalytic Reduction Systems

Daniyal Khan*, Jesper Holm Bjernemose, Ivar Lund
Department of Mechanical and Electrical Engineering
University of Southern Denmark, Denmark

ABSTRACT

Selective Catalytic Reduction (SCR) is a technique based on urea-water solution (uws) to reduce nitrogen oxides (NO_x) emitted from diesel engines. In this work, experimental investigation on injection of water and uws spray interaction with a hot mixer plate in exhaust gas test bench is presented. The work was performed with a commercial six-hole pressure-driven injector dosing into a flow channel emulating typical diesel exhaust flow conditions. Kinetic properties of the droplets were studied using Phase Doppler Anemometry (PDA) measuring the droplet sizes and velocities prior to the wall impingement. Based on these, characterization of the influence of gas velocity, fluid flow rate and change of spray fluid from water to uws was deduced. A decrease in the spray cooling effect was observed when the gas velocity was increased due to increased interaction of the droplets with the gas flow before impingement. An increase in the gas velocity results in higher wall temperatures and a higher spray mass flow shifts the spray/wall interaction regime towards deposition for smaller droplets. The breakup regimes are seen to shift from rebound and thermal breakup to deposition and splash on reaching a steady state wall temperature.

Keywords: emissions, spray, heat transfer, urea-water solution, selective catalytic reduction, mixer plate

NONMENCLATURE

Abbreviations

| | |
|-----------------|-------------------------------|
| SCR | Selective Catalytic Reduction |
| NO _x | Nitrogen Oxides |
| UWS | Urea Water Solution |
| PDA | Phase Doppler Anemometry |

| | |
|-----------------|--------------------------|
| CA | Cone Angle |
| <i>Symbols</i> | |
| \bar{D} | Mean diameter |
| n | Spread parameter |
| u_d | Initial droplet velocity |
| \dot{m}_{air} | Mass flow of air |

1. INTRODUCTION

SCR is a promising technique to reduce NO_x emissions as per compliance with the stringent emission regulations [1]. This technique includes spraying of uws (32.5% urea solution) in the exhaust gas upstream the SCR catalyst. These droplets undergo water evaporation, urea thermolysis, hydrolysis of Isocyanic acid and NO_x reduction reactions over catalyst [1]. The behavior of uws spray in the heated environment plays a major role and incomplete decomposition of uws leads to deposits [2, 3].

In SCR system, multiple phenomena occur simultaneously. First, a spray is injected into a turbulent flow. The individual droplets in the spray interact with each other before interacting with the gas flow. When the flow impinges on the surface, various scenarios can occur depending mainly on the droplet velocity and wall temperature. The hydrodynamics of drop and spray impact are governed by inertia, surface tension and viscosity. In literature, several investigations have been dedicated to understanding and modeling the spray and drop impact [4-7]. Phenomena such as film formation and single droplet wall interaction have already been studied to better get an understanding of the hydrodynamics of the droplets [8-14]. Formation of solid deposits has also been studied in [14-16].

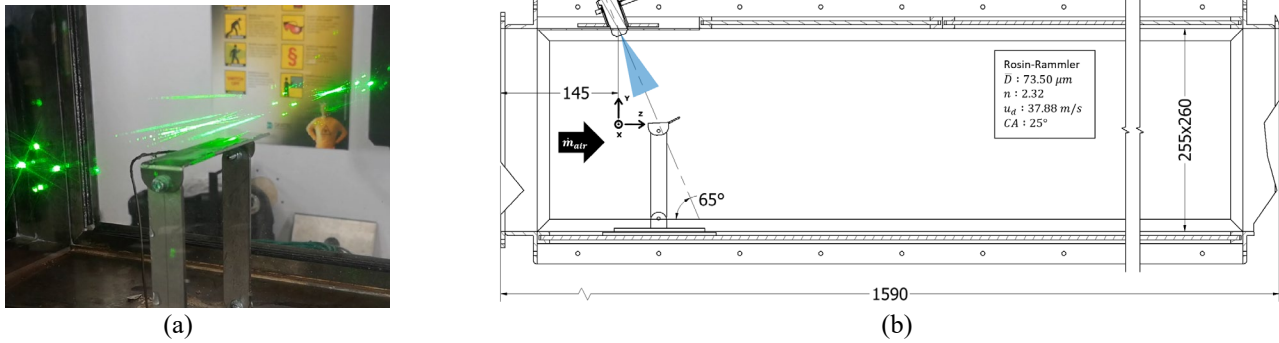

Fig. 1. (a) PDA measurements conducted on the mixer plate (b) Cross-section through the flow section axis indicating the location and orientation of the injection angles, windows and coordinate system. All the lengths are given in mm.

Temperature dependent impact regimes play a crucial part in determining the risk of deposit formation such as solid urea, biuret, cyanuric acid, ammelide, ammeline and melamine [17-19]. Fig. 2 explains the classification of spray/wall interaction into four regimes, based on Mundo number K and the temperature of the wall $T^* = T_{wall}/T_{sat}$.

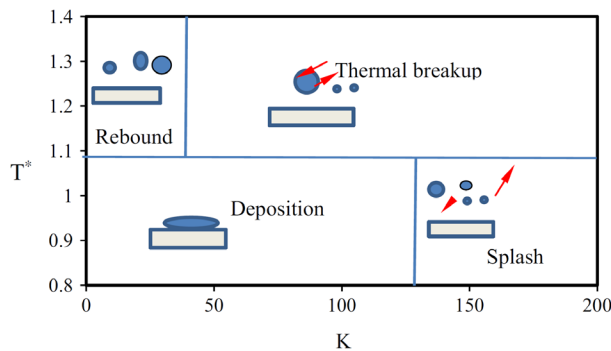

Fig. 2. Regime map for uws of spray/wall interaction (redrawn according to [20])

Deposition: If the characteristic wall temperature T^* is less than 1.1 and droplet velocity is low, then the droplets impact on wall and create a wall film.

Splash: If the wall temperature T^* is less than 1.1 and the velocity of the impacting droplet is higher, the particles break up into smaller secondary droplets after the impact. A fraction of the droplet mass forms wall film.

Rebound: At higher wall temperatures ($T^* > 1.1$) and low impact velocity, a vapor layer between droplet and wall is formed. At this high wall temperature, no wall film occurs.

Thermal breakup: At higher wall temperatures ($T^* > 1.1$) and higher impact velocity, the droplet also disintegrates into secondary droplets without any wall film formation.

The main objective of this study was to present the experimental characterization of impinging droplets on a mixer plate. A previous study has proved that water

spray and UWS spray behave similarly in terms of bulk spray properties [21]. This study is intended to contribute further to understanding the fate of the droplet and the spray/wall interactions in SCR systems.

2. EXPERIMENTAL PROCEDURE

2.1 Experimental setup

Measurements were conducted in a specially designed heated crossflow wind tunnel. The wind tunnel could maintain temperatures between 20-400 °C with flow rates ranging 0-1200 kg/h, equating to 0-10 m/s of air velocity in the test section. Details on the wind tunnel can be found in [22]. The six-hole commercial injector was mounted on the top of the section at an angle of 65° as can be seen in Fig. 1 (b) along with the Rosin-Rammler parameters of the spray. The injected mass hits a target with an axial distance between the injector tip and start of the plate is 180 mm. The target is a rectangular plate of 90 x 25 mm with the standard thickness of 1 mm. A thermocouple was mounted on the bottom surface of plate to record temperature. The designed test matrix stating all the experimented scenarios can be seen in Table 1.

2.2 Theory/calculation

PDA was used to measure the droplet velocities and diameters (Fig. 1 (a)), which could help calculate the Mundo numbers. Mundo number is a parameter describing the spray/wall interaction regime and can be calculated as follows [16, 20]:

$$K = \frac{(\rho D)^{3/4} U^{5/4}}{\sigma^{1/2} \mu^{1/4}}$$

where ρ , D , U , σ and μ denote the density, diameter, normal velocity, surface tension and dynamic viscosity of the droplets respectively.

Table 1. Test matrix

| Case | Crossflow Temperature [°C] | Crossflow Velocity [m/s] | Spray massflow [kg/h] | Fluid |
|------|----------------------------|--------------------------|-----------------------|-------|
| a | 300 | 5.5 | 1.6 | Water |
| b | 300 | 5.5 | 2.1 | Water |
| c | 300 | 8.0 | 1.6 | Water |
| d | 300 | 5.5 | 1.6 | UWS |

3. RESULTS AND DISCUSSION

Fig 3. shows the mixer plate temperature plotted against start of injection (SOI). As can be seen, with an increase in crossflow velocity the initial temperature gradient becomes less steep and the spray cooling effect decreases resulting in a higher steady state temperature than with low crossflow velocities. This also implies that with an increase in crossflow velocity the heat loss to the ambient becomes less important with respect to the

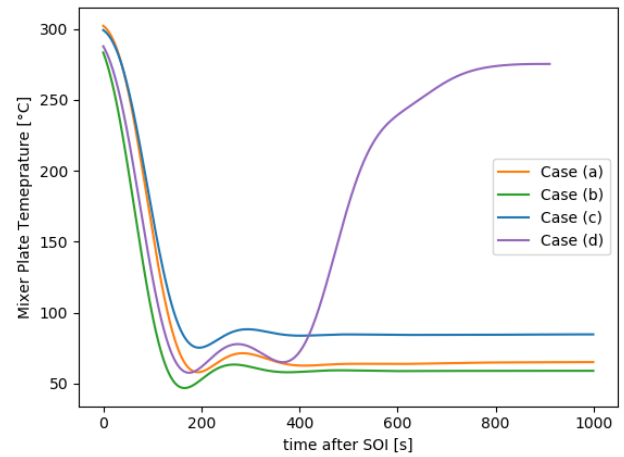
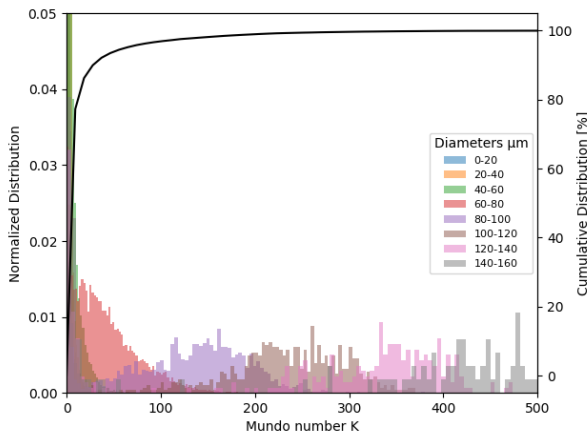

Fig. 3. Mixer plate temperature against time after (SOI)

incoming heat flux. In case of low crossflow velocities, the steady state temperature settles at around 65 °C. At a higher spray mass flow, the temperature is only slightly affected. For case (d), only temperature response was

a) 300 °C, 5.5 m/s, 1.6 kg/h of massflow of water



b) 300 °C, 5.5 m/s, 2.1 kg/h of massflow of water

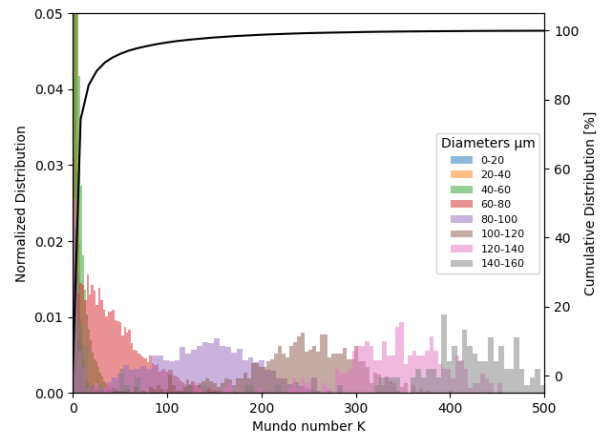

c) 300 °C, 8.0 m/s, 1.6 kg/h of massflow of water

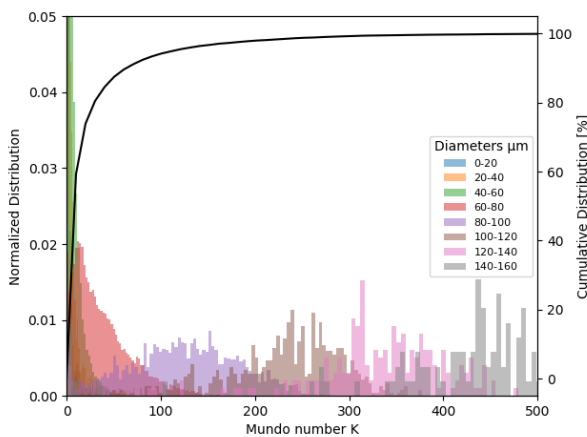

d) 300 °C, 5.5 m/s, 1.6 kg/h of massflow of uws

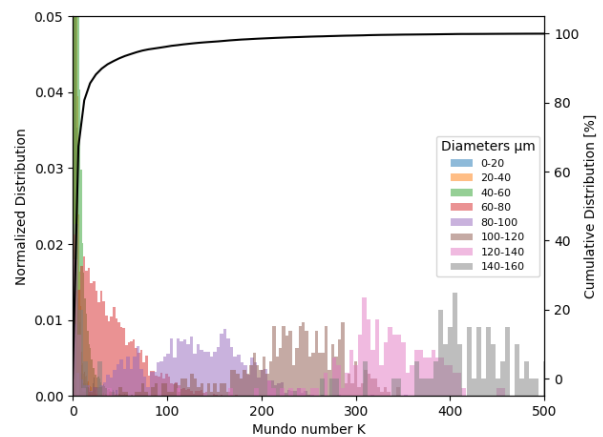

Fig. 4. Mundo number K estimated from PDA measurements at different flow rates at 15 mm above the mixer plate

recorded and thus, dosing of the spray was stopped as soon as the steady state temperature was touched.

Mundo numbers were calculated for the scenarios stated in Table 1 and plotted according to the diameter class as shown in Fig. 4. It was seen that small droplets have low Mundo numbers and large droplets have high Mundo numbers. With the same crossflow temperature, a decrease in the air velocity flattens out the Mundo distribution, while the maximum Mundo number remains constant. This is mainly because of evaporation of smaller droplets has already occurred due to an increased gas flow and larger droplets dominate the distribution. At the same temperature and crossflow velocity, an increase in liquid mass flow slightly increases the frequencies of all droplets. When the injection fluid is changed from water to uws, the distribution of the droplets becomes denser with a reasonable increase in the peaks of small and large droplets. This is largely because water evaporates first from uws droplets resulting in slow overall evaporation as compared with water droplets. It can also be seen from Fig. 4 that over 90% of the droplets possess Mundo numbers ranging from 0 to 100 regardless of the airflow speed, liquid flow rate or the injection medium to be water or uws.

4. CONCLUSIONS

A brief investigation on the impinging droplets of an SCR spray was performed. The kinetic properties of the droplets prior to the wall interaction were recorded using PDA in heated crossflow conditions.

The spray/wall heat transfer is not only dependent on the wall temperature, but also on the kinetic properties of the droplets. For most of the droplets, the principal interaction behavior is deposition below the critical temperature and rebound and thermal breakup above the critical temperature.

It is worth mentioning that the plate temperature alone is not the sole factor that determines the spray/wall interaction regime and further investigation on spray heat flux using 1D heat transfer approach or numerical simulation can be performed to investigate all the heat transfer characteristics of the spray/wall interaction.

ACKNOWLEDGEMENT

This work was financed by the project "Kompakt mixer med lav termisk masse" (Compact Mixer with low thermal mass) which is funded by the Ministry of Environment of Denmark, Ecoinnovation (MUDP). We would also like to thank Dinex A/S for providing us their facility to conduct experiments in Middlefart, Denmark.

REFERENCE

- [1] Koebel, M., M. Elsener, and M. Kleemann, *Urea-SCR: a promising technique to reduce NOx emissions from automotive diesel engines*. Catalysis today, 2000. **59**(3-4): p. 335-345.
- [2] Munnannur, A., M. Chiruta, and Z.G. Liu, *Thermal and fluid dynamic considerations in aftertreatment system design for SCR solid deposit mitigation*. 2012, SAE Technical Paper.
- [3] Strots, V.O., et al., *Deposit formation in urea-SCR systems*. SAE International Journal of Fuels and Lubricants, 2010. **2**(2): p. 283-289.
- [4] Yarin, A.L., *Drop impact dynamics: splashing, spreading, receding, bouncing....* Annu. Rev. Fluid Mech., 2006. **38**: p. 159-192.
- [5] Cossali, G., M. Marengo, and M. Santini, *Single-drop empirical models for spray impact on solid walls: a review*. Atomization and Sprays, 2005. **15**(6).
- [6] Josserand, C. and S.T. Thoroddsen, *Drop impact on a solid surface*. Annual review of fluid mechanics, 2016. **48**: p. 365-391.
- [7] Liang, G. and I. Mudawar, *Review of drop impact on heated walls*. International Journal of Heat and Mass Transfer, 2017. **106**: p. 103-126.
- [8] Nishioka, A., et al., *A study of a new aftertreatment system (2): control of urea solution spray for Urea-SCR*. 2006, SAE Technical Paper.
- [9] Postrioti, L., et al., *A methodology to investigate the behaviour of urea-water sprays in high temperature air flow for SCR de-NOx applications*. Fuel, 2015. **150**: p. 548-557.
- [10] Shahariar, G. and O.T. Lim, *A study on urea-water solution spray-wall impingement process and solid deposit formation in urea-SCR de-NOx system*. Energies, 2019. **12**(1): p. 125.
- [11] Shahariar, G.H. and O.T. Lim, *Investigation of urea aqueous solution injection, droplet breakup and urea decomposition of selective catalytic reduction systems*. Journal of Mechanical Science and Technology, 2018. **32**(7): p. 3473-3481.
- [12] Spiteri, A., et al., *Comparative analysis on the performance of pressure and air-assisted urea injection for selective catalytic reduction of NOx*. Fuel, 2015. **161**: p. 269-277.
- [13] Stritzke, F., et al., *Ammonia concentration distribution measurements in the exhaust of a heavy duty diesel engine based on limited data absorption tomography*. Optics express, 2017. **25**(7): p. 8180-8191.
- [14] Prabhu, S.S., et al., *An experimental and numerical study on effects of exhaust gas temperature*

and flow rate on deposit formation in Urea-Selective Catalytic Reduction (SCR) system of modern automobiles. *Applied Thermal Engineering*, 2017. **111**: p. 1211-1231.

[15] Xu, L., et al., *Laboratory and engine study of urea-related deposits in diesel urea-SCR after-treatment systems*. SAE Transactions, 2007: p. 202-209.

[16] Birkhold, F., et al., *Modeling and simulation of the injection of urea-water-solution for automotive SCR DeNOx-systems*. *Applied Catalysis B: Environmental*, 2007. **70**(1-4): p. 119-127.

[17] Birkhold, F., et al., *Analysis of the injection of urea-water-solution for automotive SCR DeNOx-systems: modeling of two-phase flow and spray/wall-interaction*. SAE Transactions, 2006: p. 252-262.

[18] Bernhard, A.M., *Catalytic urea decomposition, side-reactions and urea evaporation in the selective catalytic reduction of NOx*. 2012, ETH Zurich.

[19] Schaber, P.M., et al., *Thermal decomposition (pyrolysis) of urea in an open reaction vessel*. *Thermochimica acta*, 2004. **424**(1-2): p. 131-142.

[20] Kuhnke, D., *Spray/wall interaction modelling by dimensionless data analysis*. 2004: Shaker.

[21] Spiteri, A. and P. Dimopoulos Eggenschwiler, *Experimental fluid dynamic investigation of urea–water sprays for diesel selective catalytic reduction–DeNOx applications*. *Industrial & Engineering Chemistry Research*, 2014. **53**(8): p. 3047-3055.

[22] Khan, D., et al., *Design and Construction of an Open Loop Subsonic High Temperature Wind Tunnel for investigation of SCR dosing systems*. *International Journal of Thermofluids*, 2021: p. 100106.