

Exploring Japan's Domestic Green Hydrogen Production Strategy in the 2030s[#]

Tianhong Zhang^{*}, Masahiro Mae, Ryuji Matsuhashi

The University of Tokyo

(Corresponding Author: tenkozhang@gmail.com)

ABSTRACT

In this research, a solar/wind hybrid energy system assisted with battery storage was proposed to study Japan's strategies for domestic green hydrogen production in the 2030s. A LP optimization model of the proposed system was developed, and calculations were done using ERA5 meteorological data. A comprehensive sensitivity analysis and a comparison with overseas production in western Australia were also conducted.

Keywords: green hydrogen production, economic assessment, optimization, linear programming

NONMENCLATURE

Abbreviations

LP	Linear Programming
CAPEX	Capital Expenditure
FOM	Fixed Operation & Maintenance Cost
VOM	Variable Operation & Maintenance Cost
WACC	Weighted Average Cost of Capital

Symbols

L	lifetime
η_{dis}	self-discharge rate of battery
η_{in}	charge efficiency of battery
η_{out}	discharge efficiency of battery
γ	efficiency of electrolysis
δ	minimum load level of electrolysis

1. INTRODUCTION

Japan formulated the world's first national hydrogen strategy, Basic Hydrogen Strategy, in 2017 to promote the utilization of hydrogen. In light of changes of both domestic and international circumstances, such as the declaration of carbon neutrality by 2050 and the Ukraine conflict, Basic Hydrogen Strategy was revised in June 2023[1].

For Japan, it would be ideal to focus on the usage of green hydrogen and establish domestic production as well as overseas imports. Arguably, there are 3 reasons:

it could promote green hydrogen usage which has lower carbon intensity; it could improve the extremely low energy self-sufficiency of Japan (now around 12%); it would be beneficial for domestic economy. However, in the revised Basic Hydrogen Strategy, domestic green hydrogen production was mentioned, but with neither a concrete plan nor enough attention that it deserves.

The objective of this study is to explore strategies for domestic green hydrogen production in Japan in the 2030s. More specifically, optimal production location, system sizing and system operation are the main focus. As shown in Figure 1, for green H₂ production, a hybrid solar/wind energy system with battery storage was proposed. Power generation data was calculated from meteorological data (ERA5) and input into the optimization model of the proposed system. In-depth analysis was carried out.

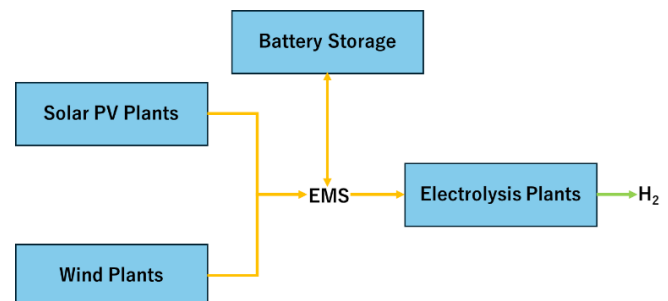

Fig. 1 Proposed energy system for green H₂ production

2. METHODS

2.1 Meteorological data, target area and period

In this research, ERA5 dataset[2] was utilized. ERA5 is the reanalysis data by ECMWF, which has a geographical resolution of 0.25°, and a time resolution of 1 hour. Meteorological data of ERA5 was processed into power generation data of Solar PV Plants and Wind Plants using the python library atlite[3].

The target area of calculation is the land area of the 4 major islands of Japan, namely Hokkaido, Honshu, Shikoku and Kyusyu. With the resolution of ERA5, 791 cells were selected for calculation.

[#] This is a paper for the 16th International Conference on Applied Energy (ICAE2024), Sep. 1-5, 2024, Niigata, Japan.

The target period of calculation is the year 2023. With the resolution of ERA5, 8760 hours were calculated.

2.2 Optimization model

The optimization model utilized in this research is a LP model to minimize the production cost of green hydrogen per unit, at the same time calculating the optimal capacity (sizing) and operation of each technology. The model was developed in a fashion similar to the model by Berger et al.[4]. 4 modules were implemented to represent the major technology components of the system: Solar PV Plants, Wind Plants, Battery Storage and Electrolysis Plants. Between modules 2 balancing exist: energy balance and hydrogen production balance. Hydrogen production balance was set to ensure that the total hydrogen production of 1 year to be at least 30000 t, which is 1% of Japanese government’s goal of hydrogen supply for 2030[1].

Major economic and technical assumptions are listed in Table 1, mainly adopted from the energy data sheet published by DEA[5][6]. The exchange rate between Euro and Yen was set to be 130 Yen/Euro.

Table. 1 Major economic and technical assumptions

CAPEX _{electrolysis}	0.65 MEuro/MW
CAPEX _{solar}	0.38 MEuro/MW
CAPEX _{wind}	1.04 MEuro/MW
CAPEX _{battery_stock}	0.142 MEuro/MWh
CAPEX _{battery_flow}	0.16 MEuro/MW
WACC	7%
FOM _{electrolysis}	0.026 MEuro/MW/year
FOM _{solar}	0.0095 MEuro/MW/year
FOM _{wind}	0.0126 MEuro/MW/year
FOM _{battery_stock}	0
FOM _{battery_flow}	0.00054 MEuro/MW/year
VOM _{electrolysis}	0
VOM _{solar}	0
VOM _{wind}	0.00000135 MEuro/MWh
VOM _{battery_stock}	0.0000018 MEuro/MWh
VOM _{battery_flow}	0
L _{electrolysis}	25 years
L _{solar}	40 years
L _{wind}	30 years
L _{battery_stock}	25 years
L _{battery_flow}	25 years
η_{dis}	0.00004 %/h
η_{in}	95.9%
η_{out}	95.9%
γ	50.6 MWh/tH ₂
δ	5%

3. RESULTS AND DISCUSSION

The results of domestic green hydrogen production cost in Japan in the 2030s is shown in Figure 2. The highest cost is 43.70 Yen/Nm³, the lowest cost is 23.66 Yen/Nm³ and the average cost is 38.34 Yen/Nm³. With a cost result of 25-30 Yen/Nm³ achieved in limited cells, coastal regions (for example, Aomori & Hokkaido) might be suitable places for domestic production.

As a reference, Japanese government’s price target of hydrogen supply for 2030 is 30 Yen/Nm³[1]. This target is not specifically for green hydrogen. As shown in Figure 2, in most cases, the production cost of green hydrogen alone exceeds 30 Yen/Nm³, which means that the total cost (including not only production but also storage and distribution) would almost certainly exceed the governmental price target. This suggests that to promote the usage of green hydrogen, policies that could bridge the price gap between green and cheaper gray/blue hydrogen are indispensable.

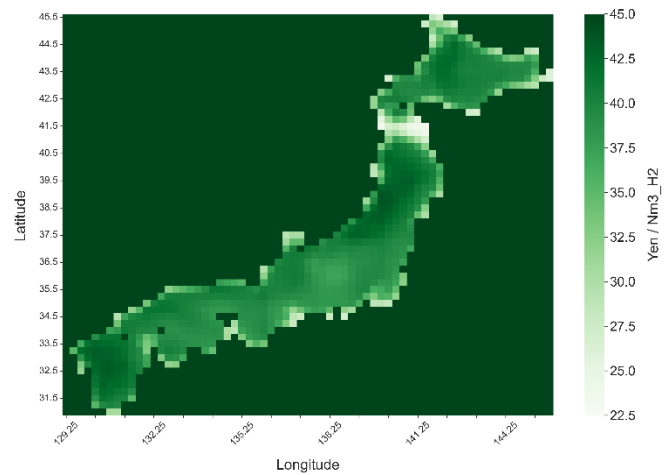

Fig. 2 Domestic green H₂ production cost in the 2030s

Next, a closer look would be taken at a certain cell that achieved a low cost. Located in Shimokita peninsula of Tohoku region, this is a cell centered in (141.25°, 41.25°). The cost result of this cell is 25.23 Yen/Nm³, which is one of the lowest in Japan. The optimal capacity of each technology is: 294 MW for wind, 196 MW for solar PV, 212 MWh for battery stock and 24 MW for battery flow, 293 MW for electrolysis. The capacity factor of electrolysis is 59%.

System operation of the same cell for 1 week is shown in Figure 3. It could be observed that Battery Storage is essential for Electrolysis Plants to meet the minimum load restriction of 5% when there were neither solar influx nor wind, for example around h=25.

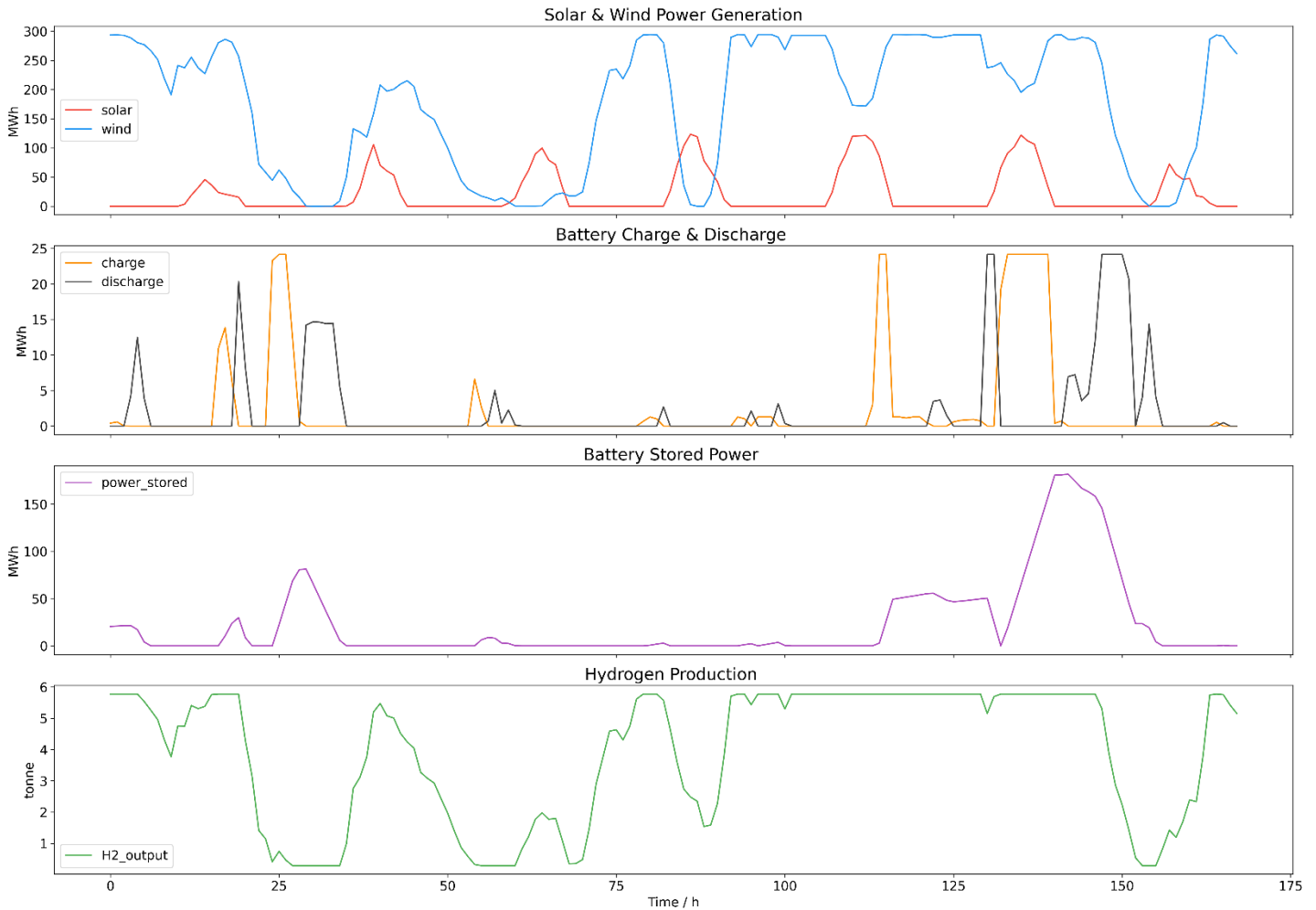

Fig. 3 System operation of the cell centered in (141.25°, 41.25°) for 1 week

A comprehensive sensitivity analysis was carried out on the same cell. 12 cases were studied: reference case, a case without WACC, cases with expensive/cheap Electrolysis Plants/Solar PV Plants/Wind Plants/Battery Storage respectively, a case where all technologies are expensive and a case where all technologies are cheap. “Expensive” means that the CAPEX and FOM of the technology is 50% higher than that of reference case, and “cheap” means that the CAPEX and FOM of the technology is 20% lower than that of reference case.

Cost breakdown for each case is shown in Figure 4. The highest cost is 37.41 Yen/Nm³ and the lowest is 20.34 Yen/Nm³. It could be observed that WACC has a tremendous influence on production cost: eliminating the 7% WACC used in the reference case would reduce the cost by 44.2%. Of the 4 technologies, the cost of Wind Plants has the most significant influence on production cost, followed by Electrolysis Plants. Raising the cost of Wind Plants by 50% could raise the production cost by 20.7%. The influence of Solar PV Plants is much less significant and that of Battery Storage

is the least significant. Raising the cost of Battery Storage by 50% would only result in a change of production cost of 2.2%.

Optimal capacity of each technology for each case is shown in Figure 5. Of the 4 technologies modeled, Solar PV Plants is the most volatile to changes in economic assumptions; its optimal capacity could change up to 67%, while other technologies’ optimal capacity would not change more than 11%.

To compare domestic and overseas production of green hydrogen, AREH (Asian Renewable Energy Hub) project [7], which is a mega project located in the Pilbara region of Western Australia for green H₂/ammonia production, was selected as a reference. 4 cells around the location of AREH were calculated using the same method. The resulting costs are between 29.17 and 30.26 Yen/Nm³. In the cell with the lowest cost, centered in (120.5°, -20.25°), the optimal capacity of each technology is: 496 MW for solar PV, 283 MW for wind, 192 MWh for battery stock and 44 MW for battery flow, 297 MW for electrolysis. The capacity factor of

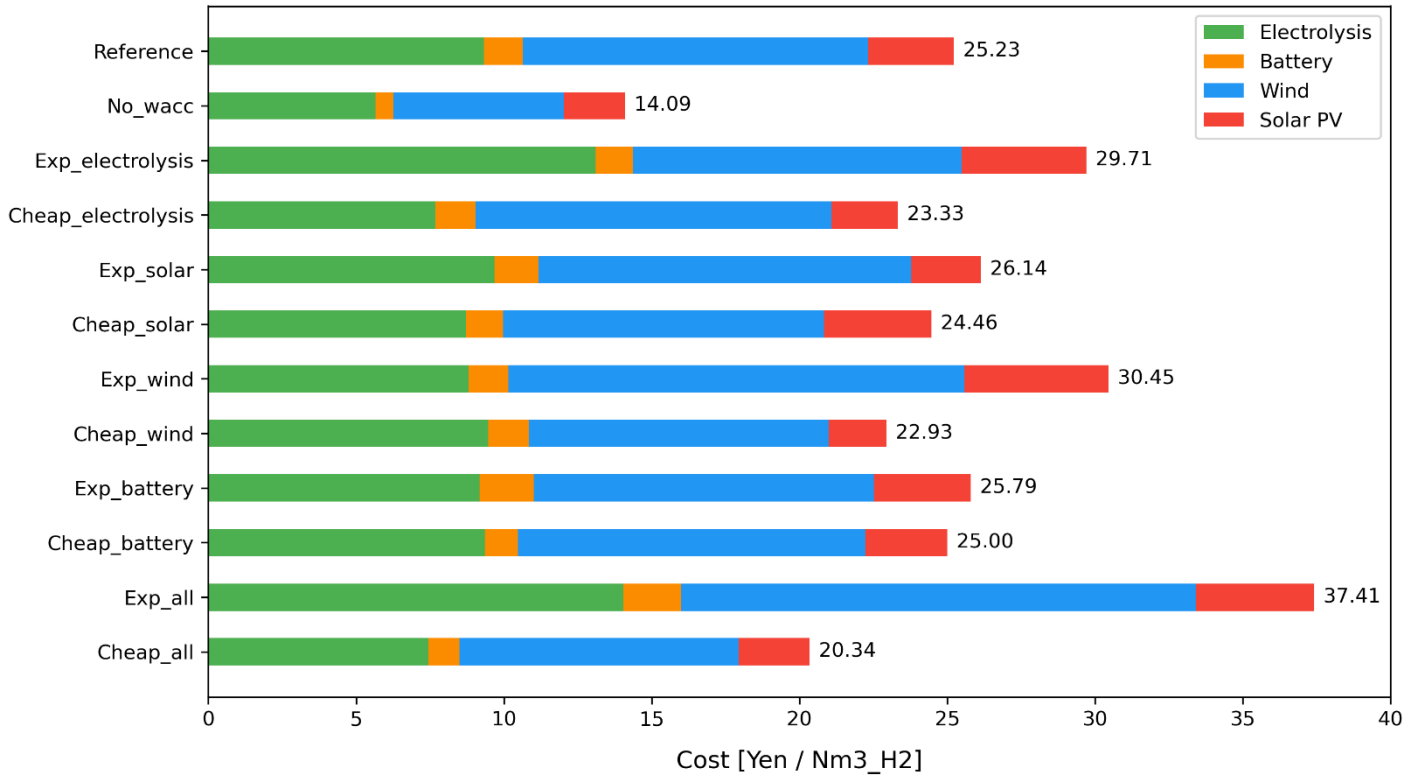

Fig. 4 Cost breakdown for each case

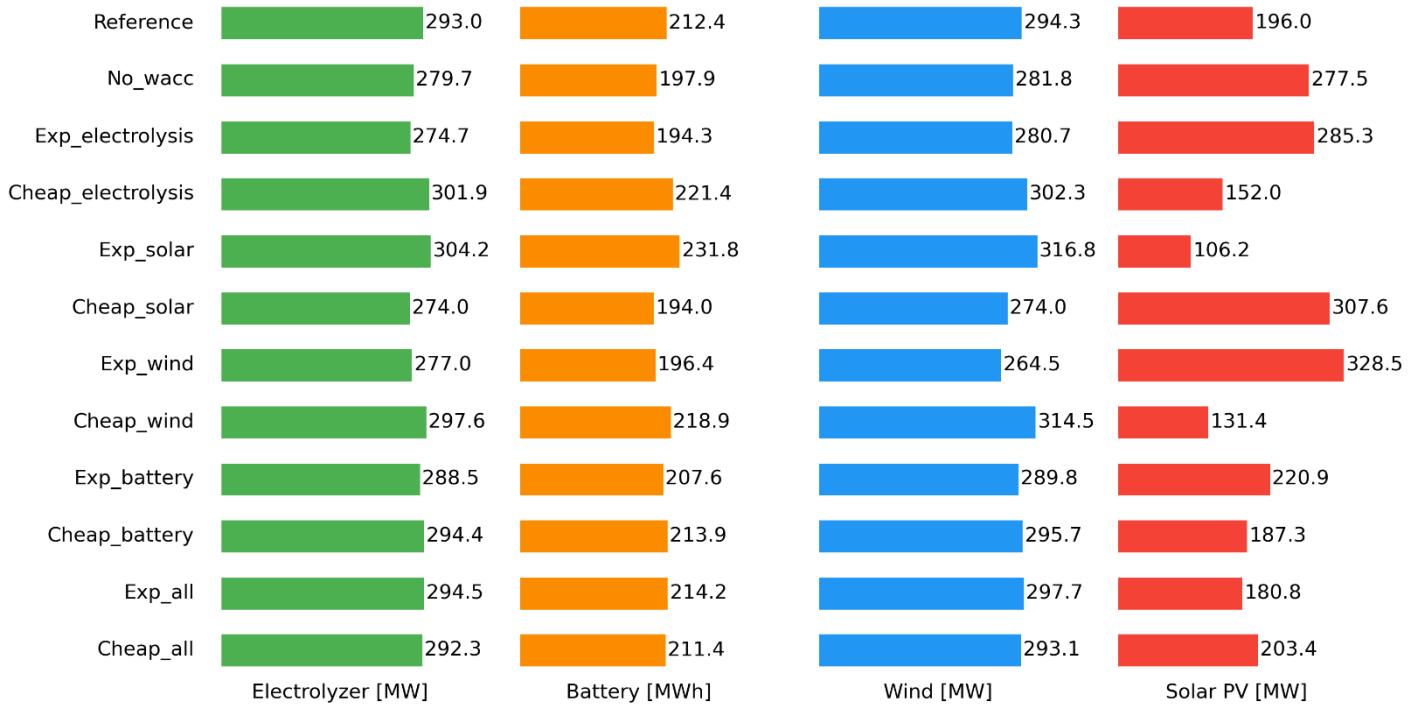

Fig. 5 Optimal capacity of each technology for each case

electrolysis is 58%. Unlike the cell in Japan studied above, power generation of AREH cells is dominated by Solar PV Plants rather than Wind Plants, which makes the system operation to be more patterned because solar influx is generally more stable than wind.

While the average cost in Japan is around 28% higher than those of AREH, although extremely limited, some cells in Japan actually yield cost results in a similar range with AREH. However, there are some points that should be taken into consideration: 1. According to Langenmayr

et al.[8], the location of AREH might not be cost optimal in Australia; 2. Due to ERA5's geographical resolution, coastal cells in Japan include some ocean areas, which might result in a higher wind speed than reality, making the cost results of these cells overly optimistic; 3. While AREH is located in a desert of flat land, Japan's land area is largely covered by mountains, which means that some cells might be unsuitable for H₂ production even if their cost results could seem promising.

4. CONCLUSION

In this research, a solar/wind hybrid energy system assisted with battery storage was proposed to explore strategies for domestic green hydrogen production in Japan in the 2030s. With meteorological data of ERA5 and a LP optimization model of the proposed energy system, domestic production cost of green hydrogen was estimated. With the cost results around 30-35 Yen/Nm³, coastal regions of Tohoku region might be promising. A comprehensive sensitivity analysis revealed that WACC influences production cost tremendously. Of the 4 technologies implemented, the cost of Wind Plants has the most significant influence on production cost and the cost of Battery Storage the least. Regarding optimal sizing of technologies, the capacity of Solar PV Plants is the most sensitive to changes in economic assumptions. The results were also compared to AREH project located in western Australia using the same method.

Calculations using data with higher geographical resolution, assessment of land use possibility in Japan worth further investigation. Supplementing the energy system with power from the power grid would be examined in the future.

ACKNOWLEDGEMENT

The authors would like to thank the anonymous reviewers for their time and patience.

REFERENCE

- [1] The Ministerial Council on Renewable Energy, Hydrogen and Related Issues. (2023, June 6). *Basic Hydrogen Strategy*. METI.
https://www.meti.go.jp/shingikai/enecho/shoene_shinene/suiso_seisaku/pdf/20230606_5.pdf
- [2] ECMWF. (n.d.). *ECMWF Reanalysis v5 (ERA5)*. ECMWF.
<https://www.ecmwf.int/en/forecasts/dataset/ecmwf-reanalysis-v5>
- [3] Hofmann, F., Hampp, J., Neumann, F., Brown, T., & Hörsch, J. (2021). atlite: A Lightweight Python Package for Calculating Renewable Power Potentials and Time Series. *Journal of Open Source Software*, 6(62), 3294.
<https://doi.org/10.21105/joss.03294>
- [4] Berger, M., Radu, D., Detienne, G., Deschuyteneer, T., Richel, A., & Ernst, D. (2021). Remote Renewable Hubs for Carbon-Neutral Synthetic Fuel Production. *Frontiers in Energy Research*, 9.
<https://doi.org/10.3389/fenrg.2021.671279>
- [5] Danish Energy Agency. (n.d.). *Technology data for renewable fuels*. Danish Energy Agency.
<https://ens.dk/en/our-services/technology-catalogues/technology-data-renewable-fuels>
- [6] Danish Energy Agency. (n.d.). *Technology data for energy storage*. Danish Energy Agency.
<https://ens.dk/en/our-services/technology-catalogues/technology-data-energy-storage>
- [7] BP Australia. (n.d.). *Australian Renewable Energy Hub*. BP Australia.
https://www.bp.com/en_au/australia/home/accelerating-australia/hydrogen/australian-renewable-energy-hub.html
- [8] Langenmayr, U., & Ruppert, M. (2023). Calculation of Synthetic Energy Carrier Production Costs with high Temporal and Geographical Resolution (Working Paper Series in Production and Energy, No. 72).
<https://doi.org/10.5445/IR/1000162460>